

ABAQUS Tutorial – 2D Truss Analysis

Problem: Determine the nodal displacements and element stresses for the truss shown below (ref. Logan's text example 3.5 pp 81-84). Use $E=30 \times 10^6$ psi and $A=2$ in². Compare to text solution: $d_{1x} = 0.414 \times 10^{-2}$ in, $d_{1y} = -1.59 \times 10^{-2}$ in, element stresses = -1035, 1471, and 3965 psi.

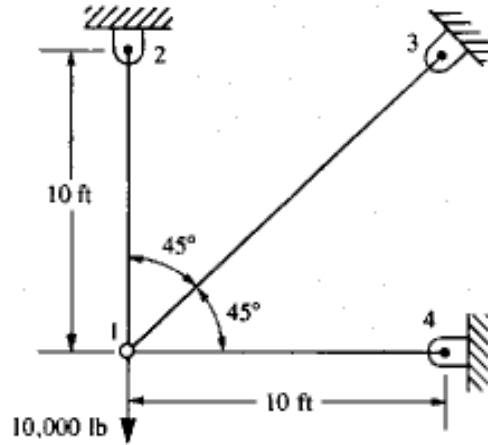

Start => All Programs => Abaqus 6.8-1 => Abaqus CAE => Create Model Database
File => Set Working Directory => Browse to find desired S: drive directory => OK

Module: Sketch

Sketch => Create => Name: truss-demo => Continue

Add => Point => enter coordinates (0,0), (120,0), (120,120), (0,120) => select 'red X'

View => Auto-Fit

Add => Line => Connected Line => select (0,0) node with mouse, then (120,0) node, right click
=> Cancel Procedure

Add => Line => Connected Line => select (0,0) node with mouse, then (120,120) node, right click
=> Cancel Procedure

Add => Line => Connected Line => select (0,0) node with mouse, then (0,120) node, right click
=> Cancel Procedure => Done

Module: Part

Part => Create => select 2D Planar, Deformable, Wire => Continue

Add => Sketch => select 'truss_demo' => Done => Done

Module: Property

Material => Create => Name: Material-1, Mechanical, Elasticity, Elastic => set Young's modulus = 30×10^6 , Poisson's ratio = 0.3 => OK

Section => Create => Name: Section-1, Beam, Truss => Continue => set Material: Material-1,
Cross-sectional area: 2

Assign Section => select all elements by dragging mouse => Done => Section-1 => OK => Done

Module: Assembly

Instance => Create => Part-1 => Independent (mesh on instance) => OK

Module: Step

Step => Create => Name: Step-1, Initial, Static, General => Continue => accept default settings => OK

Module: Load

Load => Create => Name: Step-1, Step: Step 1, Mechanical, Concentrated Force => Continue => select node at (0,0) => Done => set CF2: -10000 => OK

BC => Create => Name: BC-1, Step: Step-1, Mechanical, Displacement/Rotation => Continue => select nodes at (120,0), (120,120) and (0,120) using SHIFT key to select multiple nodes => Done => set U1: 0 and U2: 0

Module: Mesh

Seed => Edge by Number => select entire truss by dragging mouse => Done => Number of elements along edges: 1 => press Enter => Done

Mesh => Element Type => select entire truss by dragging mouse => Done => Element Library: Standard, Geometric Order: Linear: Family: Truss => OK => Done

Mesh => Instance => OK to mesh the part Instance: Yes

Module: Job

Job => Create => Name: Job-1, Model: Model-1 => Continue => Job Type: Full analysis, Run Mode: Background, Submit Time: Immediately => OK

Job => Submit => Job-1

Job => Manager => Results (enters Module: Visualization)

Plot => Allow multiple plot states

Plot => Undeformed Shape

Plot => Deformed Shape

Plot => Contours => On Deformed Shape

Result => Options => unselect "Average element output at nodes"

View => Graphics Options => Viewport Background = Solid=> Color => White (click on black tile to change background color)

Options => Common => Labels => select 'Show element labels' and 'Show node labels', set label colors to black => OK

Ctrl-C => Copies graphics window to clipboard => Paste in MS Word, etc.

Report => Field Output => Variable => Position: Unique Nodal => select U: Spatial Displacements => Apply => Unselect U

Report => Field Output => Variable => Position: Centroid => select S: Stress Components => Click on '>' and unselect all stresses except S11 => Apply

Open file 'abaqus.rpt' and cut and paste desired results into MS Word
 File => Save => enter desired file name (Abaqus will append .cae)
 File => Exit

Results:

Deformed Mesh:

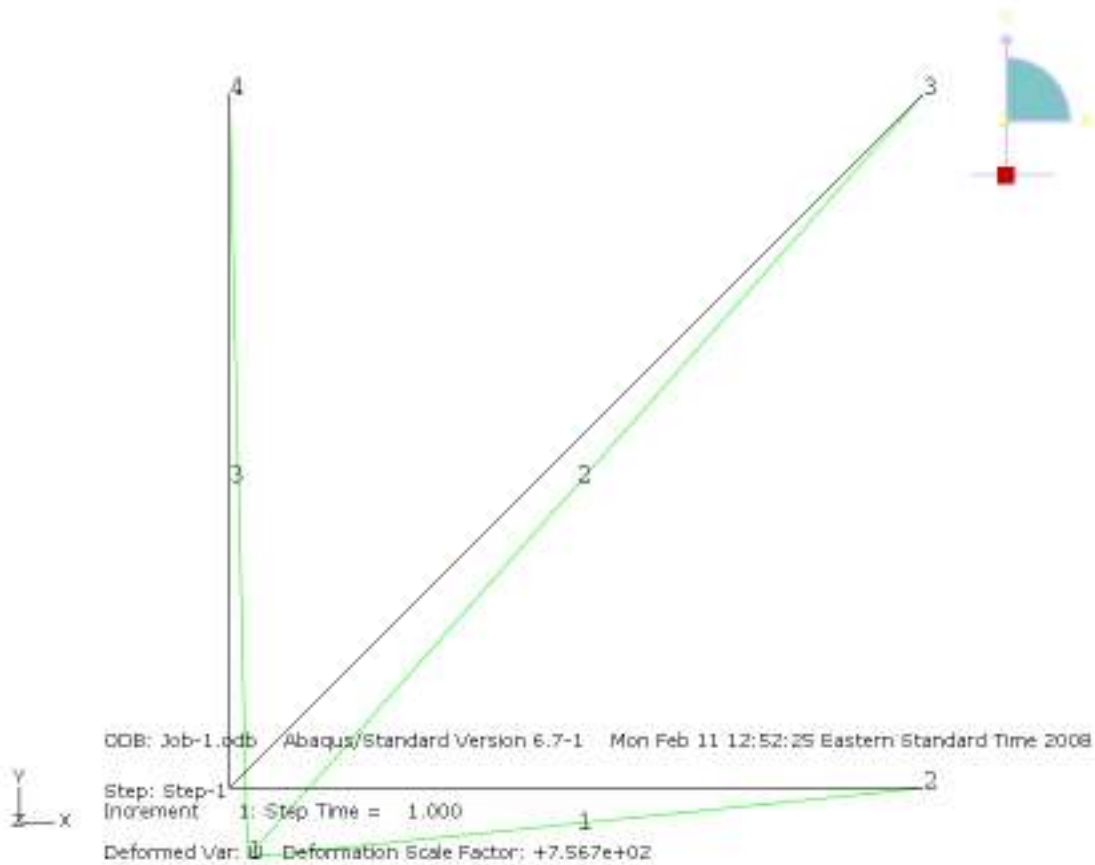

Tabulated Results (using cut and paste from abaqus.rpt)

Nodal displacements:

Node Label	U.Magnitude @Loc 1	U.U1 @Loc 1	U.U2 @Loc 1
1	16.3899E-03	4.14214E-03	-15.8579E-03
2	2.07107E-33	2.07107E-33	0.
3	2.92893E-33	-2.07107E-33	-2.07107E-33
4	7.92893E-33	0.	-7.92893E-33
Minimum At Node	2.07107E-33 2	-2.07107E-33 3	-15.8579E-03 1
Maximum	16.3899E-03	4.14214E-03	0.

At Node	1	1	2
Total	16.3899E-03	4.14214E-03	-15.8579E-03

Element Stresses:

Element Label	S.S11 @Loc 1

1	-1.03553E+03
2	1.46447E+03
3	3.96447E+03
Minimum At Element	-1.03553E+03 1
Maximum At Element	3.96447E+03 3
Total	4.39340E+03